

8a

Example of connecting several Firepoint control panels together.

In operation; if any panel goes into fire condition it will sound a continuous alarm in its own building, and cause the panels in the other buildings to pulse their alarms. Any panel can silence it's own alarm, and when the initiating panel is reset, all of the panels will reset automatically. When the panels are connected as shown below, each system can be Walk-Tested without the other panels sounding because the Fire relay is disabled in Walk-Test mode.

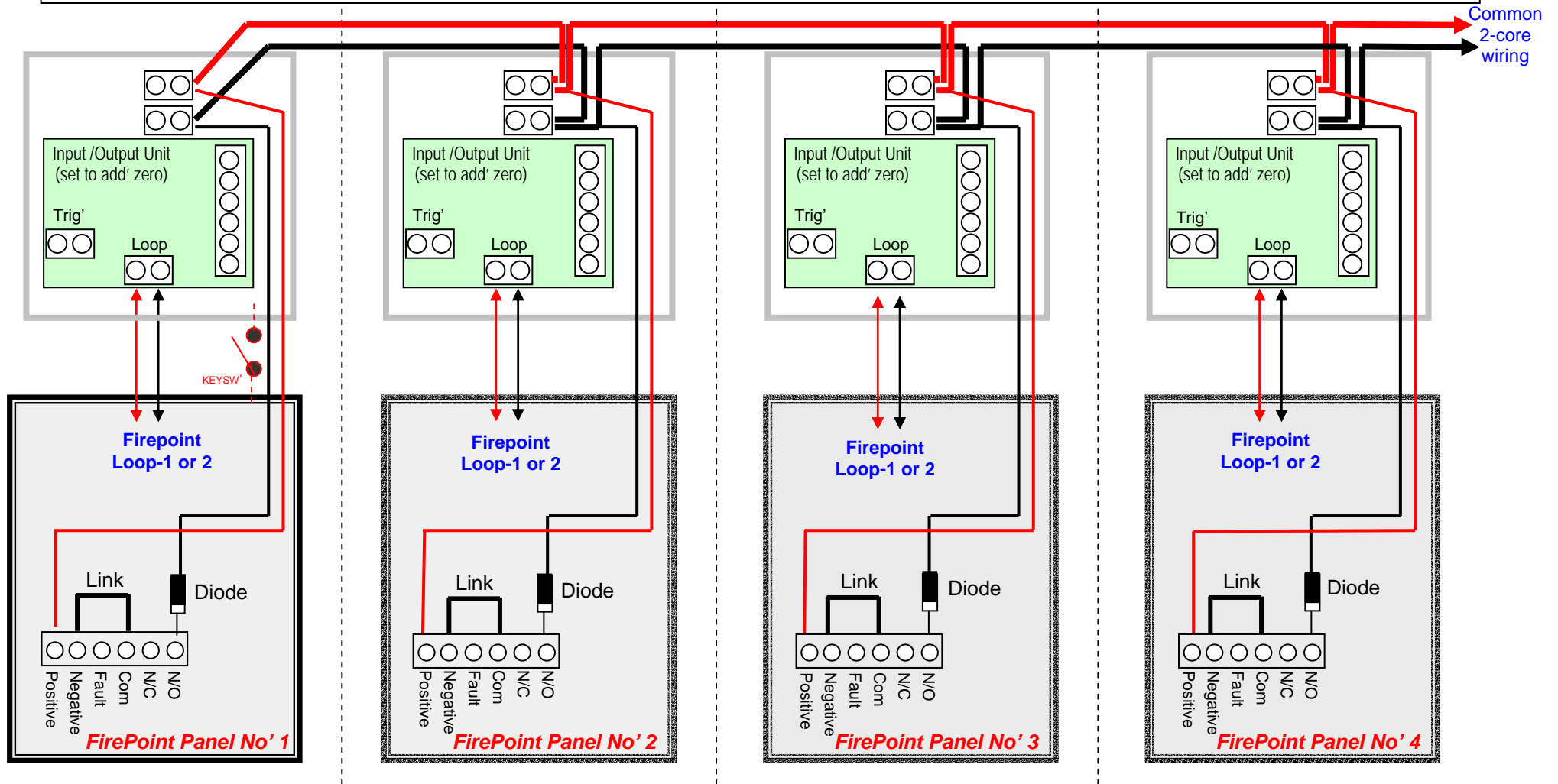

The Input/Output modules should be fitted adjacent to each FirePoint panel.

A common 2-core fire-proof cable should be run between all of the control panel positions and terminated in the Input/Output modules as shown.

4 wires are needed to be connected between the FirePoint panel and the I/O modules, these are ... 2 x from the I/O LOOP terminals to the LOOP-1 terminals in the panel.

1 x from AUX 24v positive terminal to the common positive wire.

1 x from the 1N5401 diode (supplied) to the common negative wire

The LINK and 1N5401 diode supplied must be fitted

If required, a keyswitch could be fitted into the "diode wire" to enable user-testing of the system without sounding the other panels (example shown in "Panel-No'1" above).

8b

The modification to the standard Input - Output unit for multiple-panel interconnection is as follows .....

Remove D2 from the pcb. Cut the pcb copper track between the Relay Coil and "Loop -ve" terminal.

Connect new Red & Black wires to the relay-coil pads.

Connect a new pair of wires from the Normally-Open terminals of the o/p relay, to the TRIGGER terminals.

In operation .....

When the Interconnection-Bus is activated by any panel there will be 24v on it, this will cause the relay contact to change-over thereby triggering the I.O. unit into alarm condition.

