

FirePoint-3 Installation Manual (version 5-1 v9)



Lloyds Alarms Ltd

3 Connaught Business Centre
Malham Rd. London SE23 1AH

Phone. 020- 8699 8599 Fax. 020- 8699 9290

www.firedynamics.co.uk

Section A. Menu Flowcharts

- PCB Layouts & Wiring Examples
- "Fast-Start" instructions
- The Menu Layouts
- The Function Switches

Section B. System description and Overview

- Installation Wiring
- The Detector System
- Powering up the System

Section C. Detailed Information

1. View Installed Detector Responses
2. FireGraph
3. Clock & Calendar
4. Event Log
5. Walk Test (Noisy or Silent)
6. The "Service-Timer"
7. Edit Detectors
 - Selecting Loop & Detector Number
 - Selecting Detector Type
 - Allocating Zone LED
 - Entering & Editing Text
8. Class Change
9. FIRE - FAULT - AUX. 24v & Relay Set-up
10. Detector-Removed Delay
11. Isolate Detectors
12. Installer's Text message
13. Disable Fault Buzzer
14. Auto-Testing Detectors
15. Last-Missed-Response display
16. Restarts Counter
17. Returning to Default Settings
18. Zonal Relays
19. Zonal Alarms
20. Special Walk-Test operation
21. Main Alarm Delay
22. Remote Evacuate Delay
23. Fault Finding
24. Default Settings
25. Customer Operating Instructions

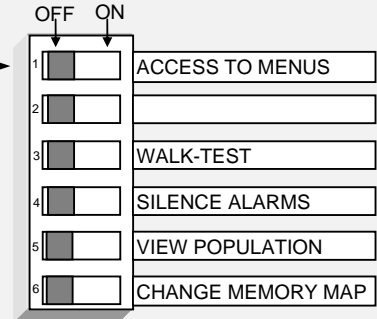

The 6 Function Switches on the PCB work as shown above

FP-3

Copies of this manual and all data sheets can be downloaded free from our website www.firedynamics.co.uk

25. Address-Code Settings & Detector Connections

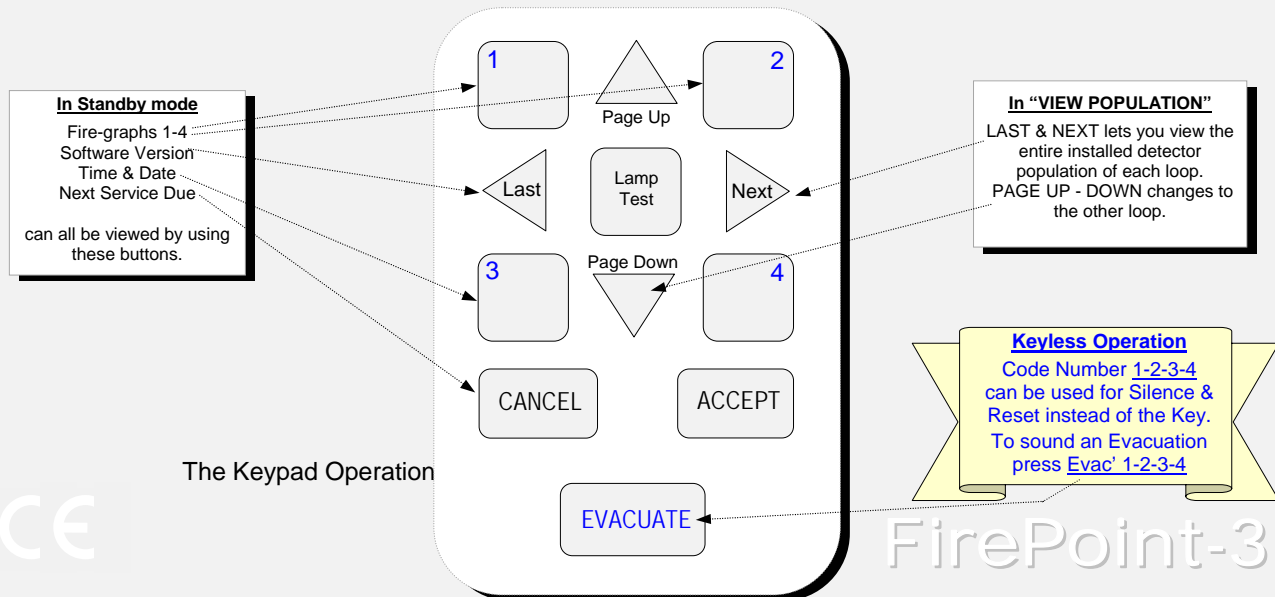

FirePoint-3

PCB Layouts and wiring examples

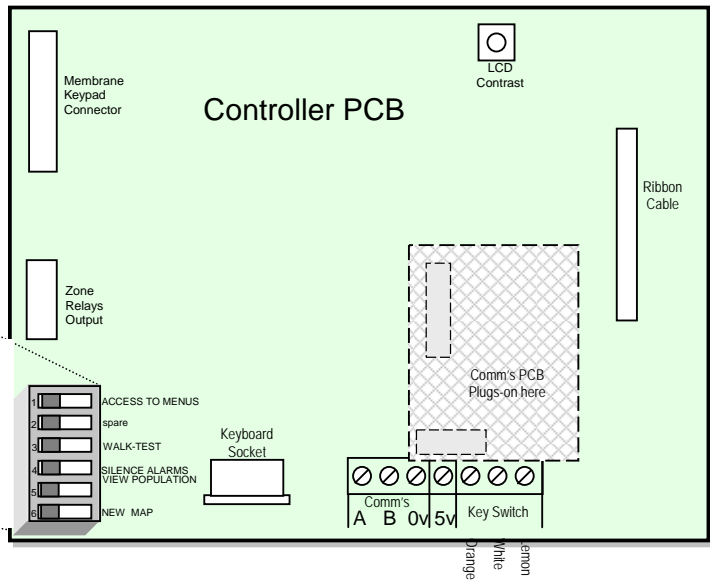
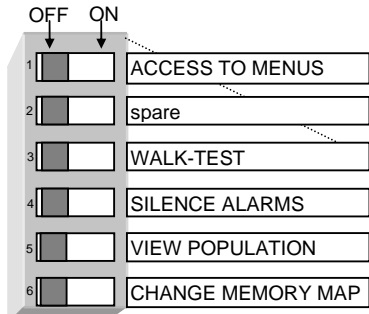

The detectors & sounders can be fitted in any order throughout the installation wiring

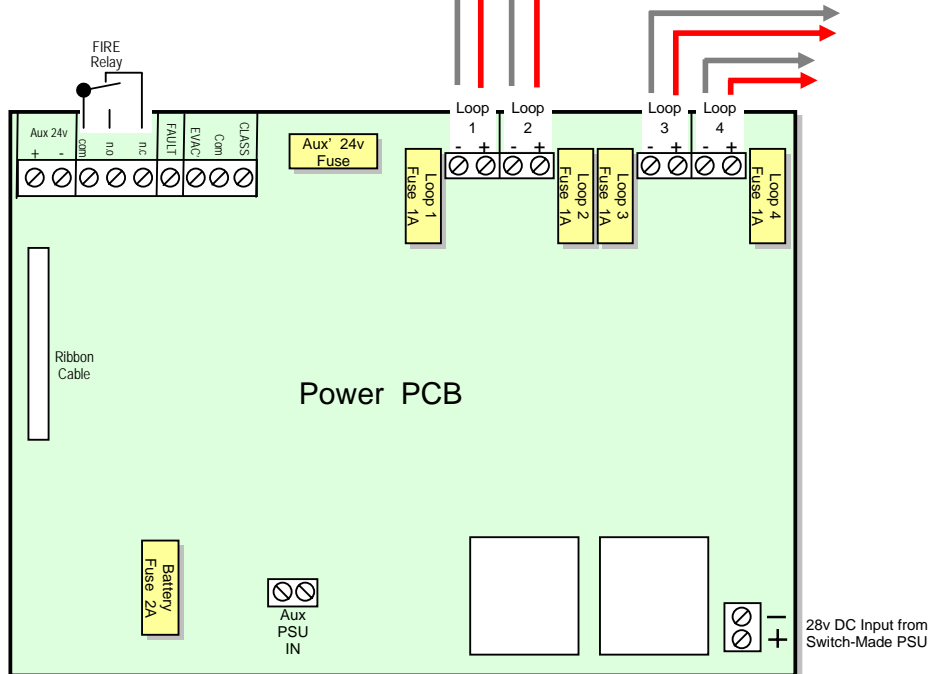
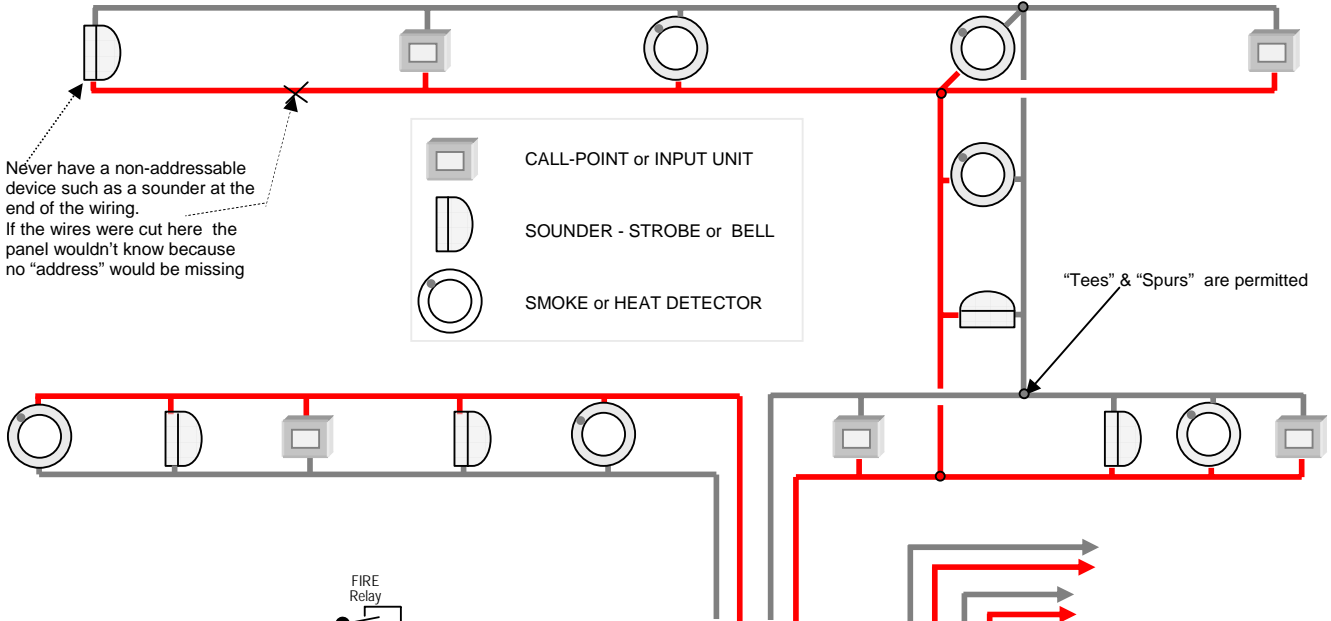

To Fast-Start the Installation (& keyboard layout)

To enable the installation to be up and running quickly it isn't necessary to enter any information for the detectors first; the system automatically displays FIRE and FAULT plus the detector address number (as shown below); The detector type, text & zone numbers, can be entered later when you are ready.

*** **REALLY HANDY TIP**Before starting the installation, fill-out the "detector-location chart" first ***

Items 1 - 3 below are all you need to do to get the system up-and-running.

1. Move "NEW MAP" switch to ON (Switch-6).
2. Set the switch's on each detector to the required "address" and install the detector on the wiring.
3. When all detectors are fitted and "MAP CHANGE DONE" shows on the screen, move switch-6 to OFF. Job Done.

Now Test the Detectors. The LCD screen will show FIRE or FAULT as below.

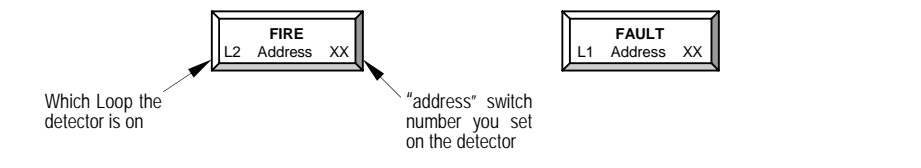

When you are ready, do the following ...

- | | |
|---|--------|
| 4. Enter "Detector Text" information | MENU-2 |
| 5. Set "Service Reminder" period | " " |
| 6. Set "Installer Text", i.e. your name & phone no' on the LCD display. | MENU-3 |

TIP. Do all text entry with Switch-6 in the ON position.

IF THE KEYBOARD SOMETIMES SEEMS A LITTLE SLOW WHEN ENTERING DATA, BE PATIENT, IT MAY BE THAT THE SYSTEM IS ALSO CARRYING OUT IT'S POLLING, MONITORING, & "HOUSEKEEPING" TASKS AS THE SAME TIME.

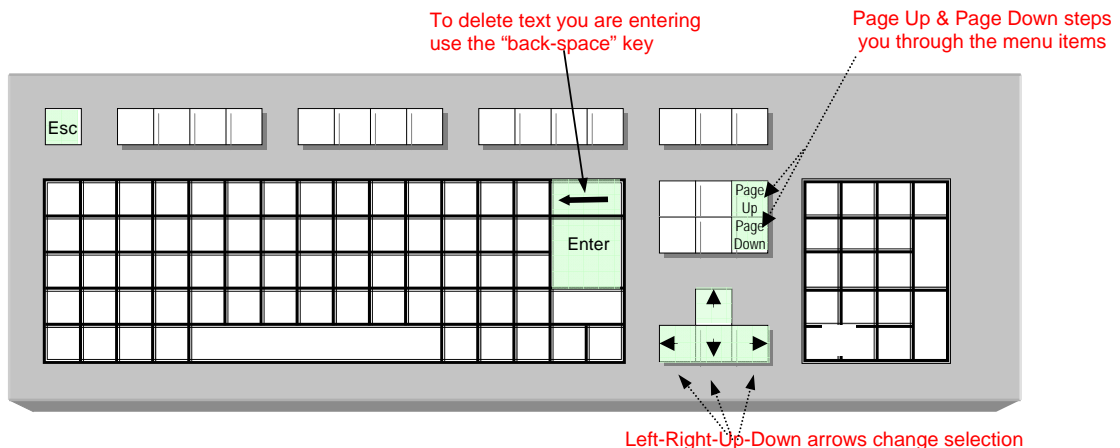

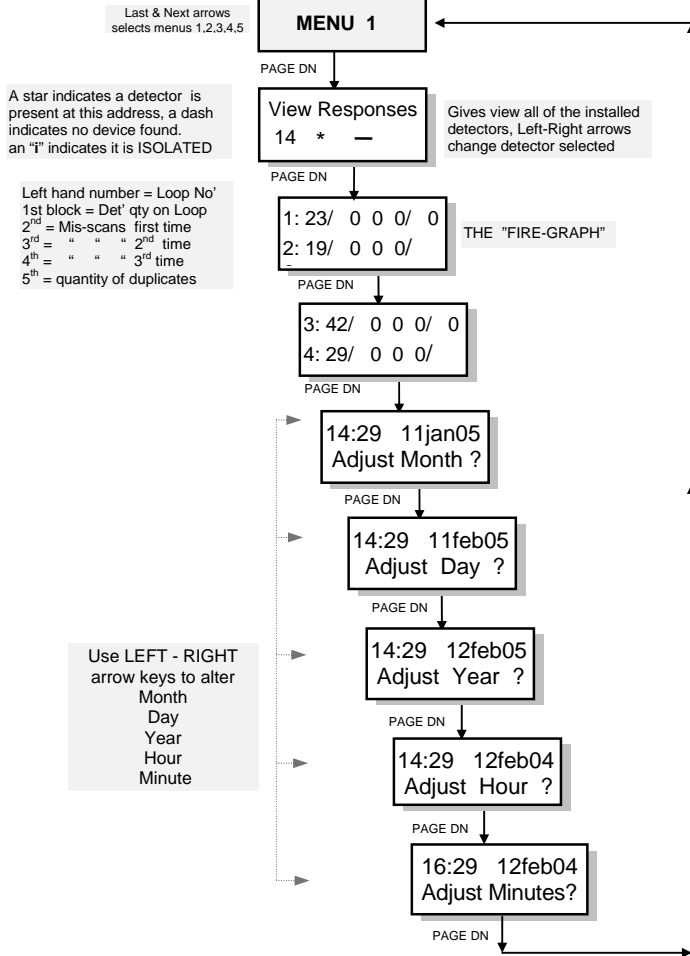

WARNING. When you are in the "VIEW RESPONSES" display the system is not polling the detectors and a fire alarm will only be shown as an "F" when you are viewing that detector number, **NO ALARMS WILL SOUND.**

MENU 1

PAGE-DN will step you down through the menu items.
LEFT - RIGHT ARROW alters the selection

To leave the MENU'S and revert to standby :-
Move switch 1 to OFF at any time.

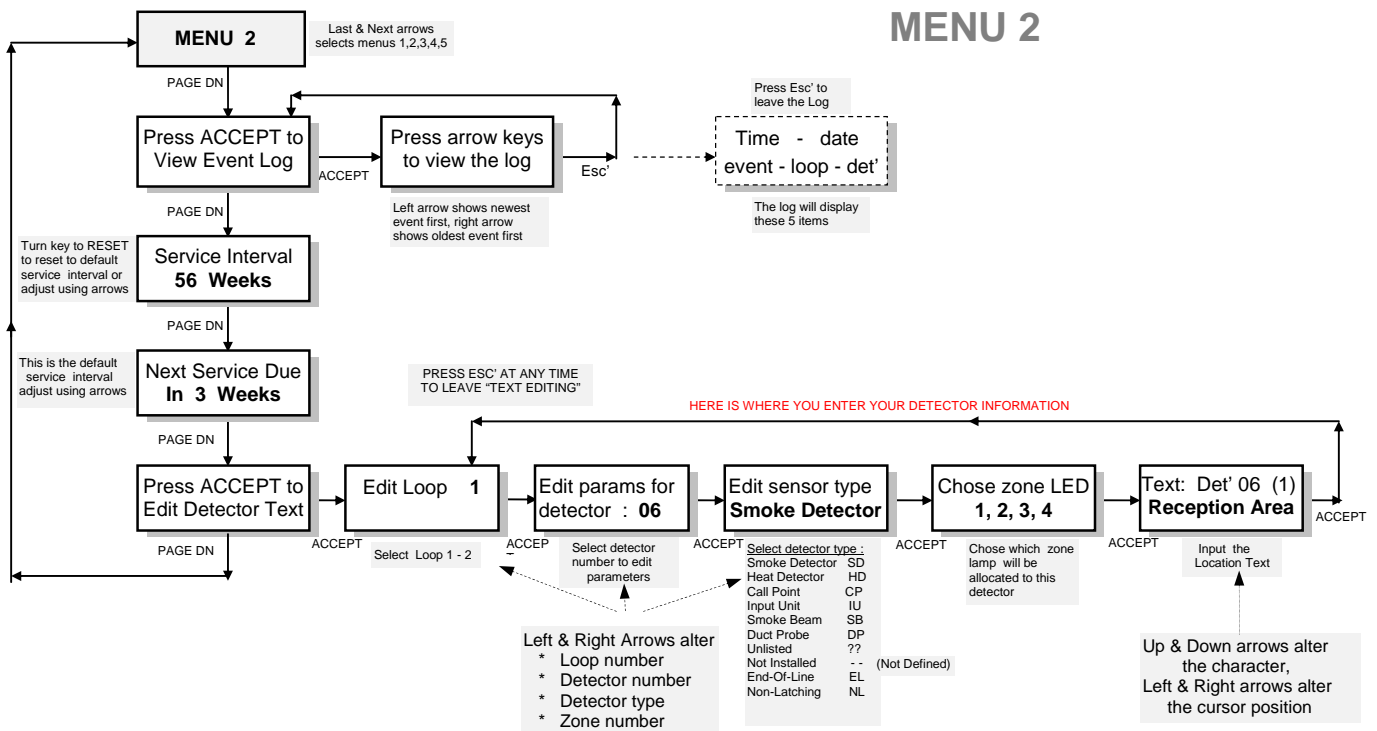

MENU 3

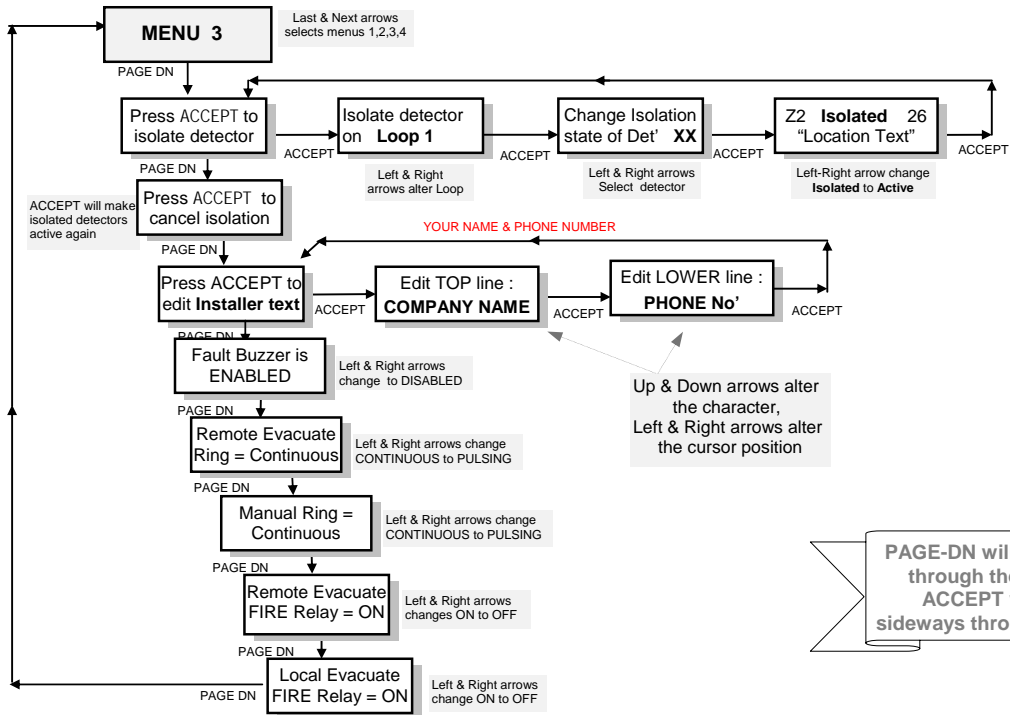

PAGE-DN will step you down through the menu items. ACCEPT will take you sideways through the selection

To leave the MENU'S and revert to standby
 :-
 Menu switch 4 to OFF at anytime

MENU 4

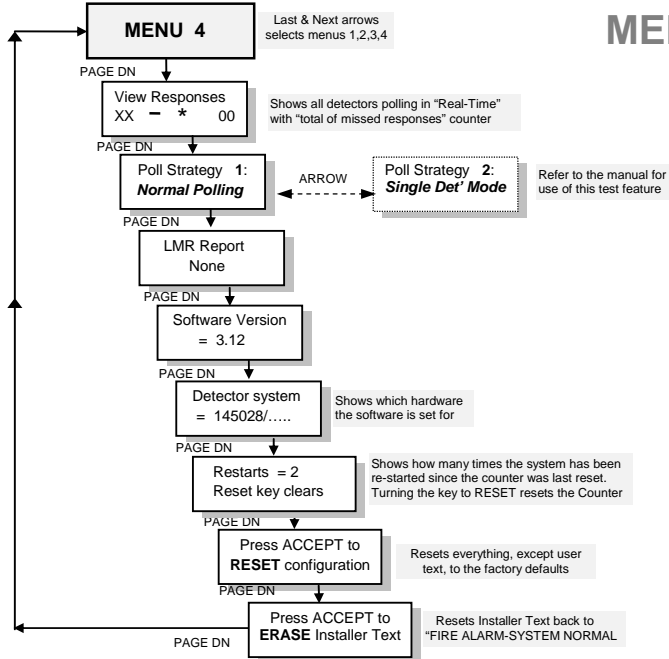

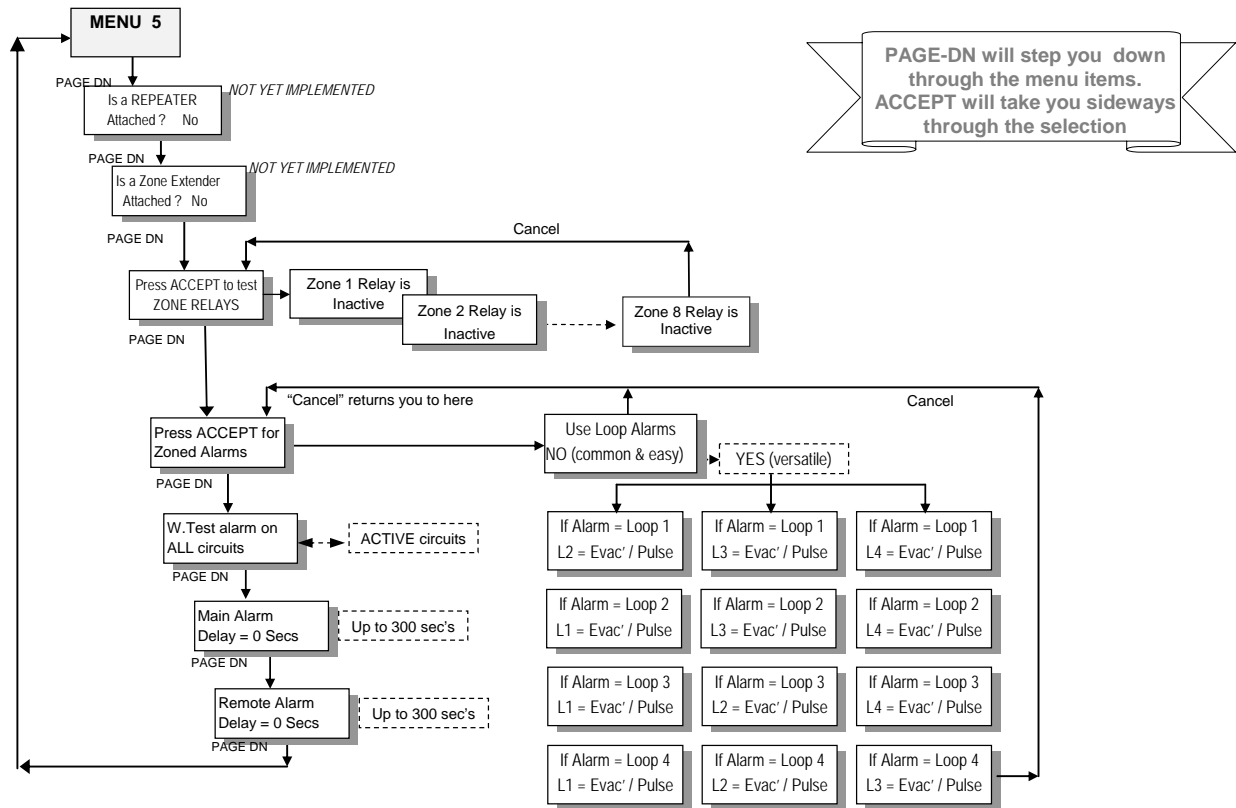

The Engineers Function Switches

Menu Mode.....Switch 1

In the ON position, this allows access to the five Menus by pressing Last / Next Arrows.

Spare.....Switch 2

Walk-Test..... Switch 3

In the ON position, the system is made non-latching so an alarm condition will reset itself when the cause is cleared, see Section 5.

Silence Alarms.....Switch 4

When this switch is ON, any alarm condition will be displayed at the control panel but no alarms will sound.

View Detector Population.....Switch 5

To view the entire installed detector population move Function Switch 5 to ON and use the four arrow keys to scroll through both Loops (A detector cannot be viewed until it is in the memory by moving switch-6 to ON first)

Change Memory Map.....Switch 6

When this switch is ON detectors may be added and removed from the system, when it is OFF the information is locked in.

NOTE.. If you are in any part of any menu, you can immediately go to any other menu by pressing ESC' plus the other menu number, e.g. Esc' and 4 will take you straight to MENU-4; you can leave the menus at any time by moving switch-1 to the OFF position.

Installation Wiring

In these instructions the term "Loop" is used to mean the 2-core fireproof cable you install throughout the building to connect the detectors and sounders to the FirePoint-3 control panel, in practice there is no need to actually form the wiring in a Loop. **If using Pirelli FP200, Firetuf, or similar type flexible cables, all of the screen (drain) wires should be firmly connected at all joints to form a continuous earthed shield to the whole wiring installation.** When upgrading an old system, if there isn't earth continuity on the existing cables, use with caution. Use separate 2-core cables for each loop throughout the installation rather than a single 4 core containing both loops in case this results in cross-channel interference; The FirePoint - 2 will accept "spurs" and "tees" off the wiring and doesn't need "end-of-line resistors". Where we use the term "Detector" we mean any smoke or heat detector, addressable base, call-point, smoke-beam, duct-probe or input unit.

To conform to BS5839 each Loop should have at least one alarm sounder and one detector fitted.

NEVER USE A MEGGER OR OTHER HIGH VOLTAGE TESTER ON THE WIRING IF THE CONTROL PANEL OR DETECTORS ARE CONNECTED; DAMAGE WILL RESULT AND THE WARRANTY WILL BE VOID. Only use a low voltage digital or analogue meter. Static electricity is extremely hazardous to electronics, walking on carpet containing nylon or other man made fibre generates large amounts of static electricity which discharges into the electronics when touched causing instant damage. If the detectors or control panel are fitted you should always earth yourself before touching any of the wiring conductors, termination screws or metal parts.

Detector system description

The FirePoint-3 is a 2 or 4 Loop addressable control panel with a capacity of 64 detectors on each loop, all detectors on the loops are polled within a 3-second period and the loops are polled in parallel to stay within this time frame. When a detector is polled or interrogated by the control panel its LED will give a short flash in reply.

All the detectors send their own unique "address code" back to the control panel which then compares it to a similar "map" in its non-volatile memory. The FirePoint-3 constantly compares those devices responding on the wiring with its memory map and if any detector should become missing this will be recognised and displayed on the LCD screen. Even when the system is de-powered the map is retained.

If you add or remove any detectors from the installation, the "NEW MAP" switch should be moved to the ON position to allow the new configuration-map to be stored in the memory, if a detector is added to the system without the memory map switch being turned ON the LCD will display "INSTALLATION AND MAP MISMATCHED".

Any detector which is set as a NON-LATCHING (NL) device in MENU-2 will only cause the sounders to pulse ON and OFF and will disable the FIRE RELAY when it is triggered into fire, in this way the FirePoint-3 can be interlinked with other fire alarm systems and prevent them "Nesting" or "Locking in a Loop".

The FIRE relay is also disabled in the Walk-Test mode so that, for example, a Red-Care communicator wouldn't be triggered or fire doors wouldn't be closed if operated via that relay.

Powering up the system

When the FirePoint-3 control panel is first powered up the mains supply should be connected first, whereon the LED's on the front panel will cascade and the buzzer sound while the internal systems initialise, this takes about 6 seconds. Next, move SWITCH-6 (NEW MAP) to the ON position and connect the battery's and the Loop wiring, after several seconds the message "MAP CHANGE DONE" will be displayed together with the detector quantity on each loop; moving SWITCH-6 back to the OFF position will lock the information into the memory.

Note! the information in the memory is retained even when the system is de-powered.

Never connect the batteries the wrong way round; damage will result which is factory detectable and not covered by the warranty.

1. VIEW RESPONSES

NOTE... While using this facility the detectors are not being polled and are inoperative, the EVACUATE switch on the front of the control panel is still fully operational.

This display shows if a detector is being "seen" at the address number on the left of the screen, by scrolling through all 64 addresses you can view all detectors on both Loops. When a detector is selected on the screen, the LED on the actual detector will remain lit enabling you to precisely determine the address number a detector is set to. Various characters may be seen on the LCD display, these are listed below.

- "*" (star) indicates a detector is present.
- "-" (dash) means no detector is being seen at that address number.
- "F" means that the detector is in FIRE condition.
- "O" means the Loop is OPEN CIRCUIT
- "S" means the Loop is SHORT CIRCUIT
- "i" means that that detector is ISOLATED.
- "M" means MULTIPLE responses i.e. you have more than one detector on a loop with the same address number setting.
- "N" means NO RESPONSE from that detector, possibly caused by the detector being removed from it's base (if the memory map expects to see a detector responding from that address location and doesn't get it it will assume that the detector is wrongly missing and give a NO RESPONSE signal).
- "?" means that the detector is NOT YET DEFINED and will not give FIRE OR FAULT signals.

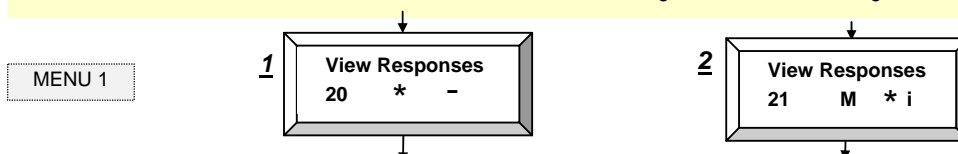

In example 1 above Loop-1 has detector number 20 installed, Loop-2 has nothing at address 20; In example 2 above detector 21 on Loop-1 has another detector on the Loop set to the same number (Multiple), and detector 21 on loop-2 is isolated (i).

2. The FIREGRAPH

This facility shows the "condition" of the signals coming back from the detectors on each loop; the top line is Loop 1, the bottom line is Loop 2.



The first number is the "Loop" number, 1: or 2:

The next number to the right is the total number of detectors being found on each loop (Loop-1 = 37, Loop-2 = 23)

The next block indicates the number of mis-responses from the detectors on the 1st scan.

The next block indicates the number of mis-responses from the detectors on the 2nd scan.

The next block indicates the number of mis-responses from the detectors on the 3rd scan.

The right hand block shows the number of duplicated addresses or un-mapped detectors on each loop.

In the example above, Loop 1 has 37 detectors, with 1 duplicate or un-mapped detector; the first scan block shows that 2 detectors mis-responded on the first cycle, one detector on the second scan, and none on the third (a FAULT condition occurs after 4 consecutive bad scans from a detector)

An occasional number in the first or second scan box is not unusual and does not necessarily indicate the presence of a fault, whilst multiple numbers in the second and third-scan boxes should be treated as early warning signs of a FAULT. In Non-Menu mode, the FireGraph can be viewed instantly by pressing button number 1 on the Keypad.

3. SET CLOCK & CALENDAR

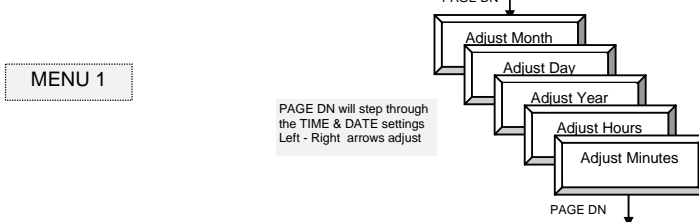

PAGE DN will step through the TIME & DATE settings
Left - Right arrows adjust

4. EVENT LOG

The event log will retain approximately the last 100 events in its memory; the log will **NOT** record Class-Change or Walk-Test events.

The log will record the Time, Date, Type of event, Loop number and Detector number; every event in the log will have first been displayed on the LCD screen when it occurred, when the log fills up the oldest event will be discarded so that the new event can be recorded.

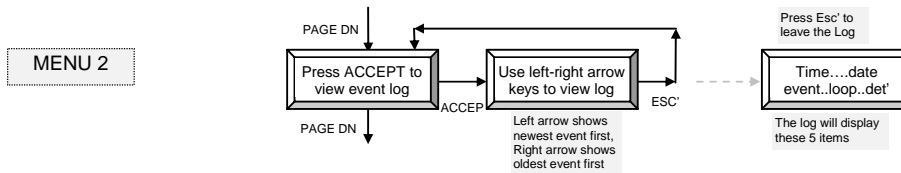

Left arrow shows newest event first,
Right arrow shows oldest event first

Press Esc' to leave the Log

The log will display these 5 items

5. WALK TEST. (NOISY or SILENT)

This facility allows the system to auto-reset from an alarm condition so that when a detector is set into FIRE the alarms will reset after 2 seconds; when the alarm condition is removed the control panel will automatically return to the standby mode, this facility allows one-man testing of the entire installation without having to manually reset the control panel each time. In Walk-Test mode the display will show "**NOISY WALK-TEST**".

In certain situations you may wish to turn the alarm sounders off during walk-test (e.g. in a hospital, office, etc, when multiple alarm sounding would be undesirable), to do this move Function Switch 4 to ON, the sounders will be silenced until switch-4 is moved back to its OFF position, during this time the display will show "**SILENT WALK-TEST**"; when a detector is triggered during noisy and silent-walk-test it's LED will pulse brightly to give a visual indication the control panel has received the signal.

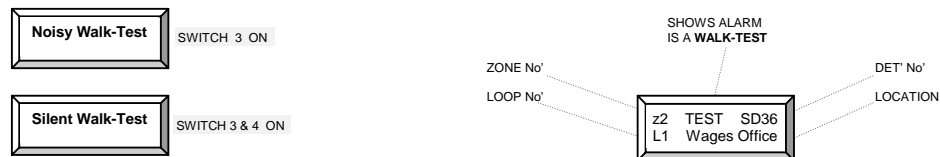

6. SERVICE TIMER & SERVICE INTERVAL

You can set the Service Timer to remind the system user when a service of the fire alarm system is due. When the service is due the FirePoint-3 will flash the fault LED's continuously and sound the internal buzzer once every 5 minutes, the display will also alternate between the message "**Maintenance Service Due**" and the "Installer message" (which may be the company name and phone number). The "Service Reminder" can be turned OFF by setting the time to zero hours, or up to 156 weeks in advance, you can also view how many weeks before the next "Service Due" reminder by seeing how far the "Next Service Due In.." has remaining or pressing button-3 on the membrane. The default service interval is 56 weeks.

When a service has been carried out, the Service Timer can be reset to it's pre-set period by going to "**Next Service Due In ...**" message and turning the control panel key-switch to RESET, whereon the display will reset to the default interval you have set and show how many weeks to the next reminder, or you can set to however many hours, days or weeks you require manually via the keypad. The "Service Due" message will disappear from the screen whenever a FIRE or FAULT message is present.

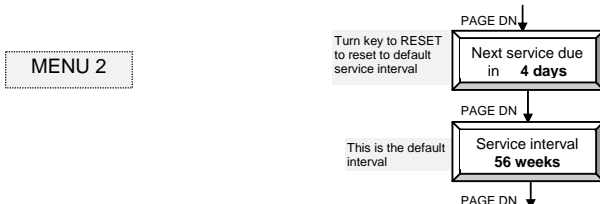

Turn key to RESET to reset to default service interval

This is the default interval

11. ISOLATE DETECTORS

To isolate a detector so that it does not respond to FIRE signals, go to Menu 3 and follow the chart below ; **NOTE.** Call-Points cannot be isolated. To de-isolate INDIVIDUAL detectors repeat the same process or to de-isolate ALL detectors simultaneously press "Press ACCEPT to Cancel Isolation" in Menu-3.

Note !... An Isolated detector will still report fault conditions

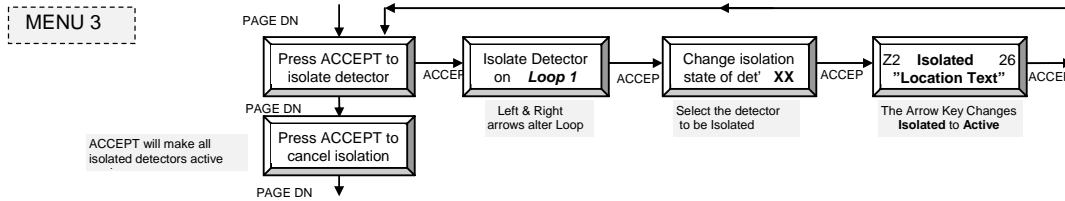

12. INSTALLERS TEXT

The "Installers Text" message is the information that will be shown on the LCD display during standby, a FAULT, or when a service is due, the message can be 2 lines of 16 characters and will usually be the company name on line 1 and the telephone number on line 2, although you can enter any message you wish with a limit of 16 characters per line.

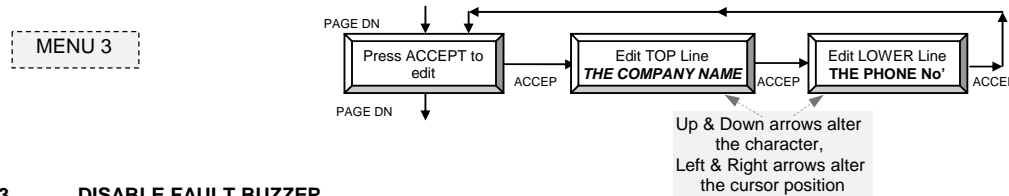

13. DISABLE FAULT BUZZER

The fault buzzer can be disabled by an option in Menu-3, the buzzer will only be muted for non-critical system faults and will still operate when there is a Main Supply, Battery, or Auxiliary 24v fault.

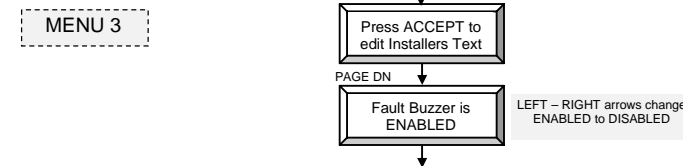

NOTE. When the buzzer is silenced and you exit Menu mode, or whenever you exit from any engineer functions, the display will show "FAULT BUZZER DISABLED" as a reminder, the screen can be cleared by turning the key-switch to RESET.

14. AUTO TESTING / SINGLE TESTING OF DETECTORS (Polling Strategy)

This is a "real-time" view of the detectors being polled and responding. In normal polling all detectors are interrogated approximately once every 3-seconds and in single-detector-polling approximately 25 times-per-second and each detector should respond every time. If a detector's response isn't within certain parameters at the control panel the number on the right will increase with each cycle, this number can be reset to zero by turning the key to RESET. This feature is purely for analysis purposes by experienced engineers and should be regarded solely as an aid to fault finding, a high number by itself means nothing, but a high number within a short period may indicate a fault, caused possibly by one of the following :-

- A faulty, or off-specification addressable device
- A bad connection on the loop wiring
- Interference being induced into the cable
- High cable capacitance or resistance
- Low resistance between cable cores

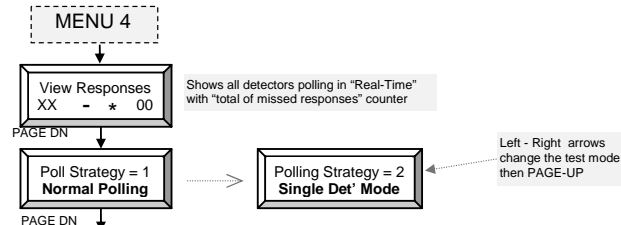

The **TEST STRATEGY** lets you change the display from auto-polling ALL detectors, to polling only a SINGLE selected detector; in this way every individual detector installed can be examined to locate the source of mis-responses; but again, these features are for the aid of knowledgeable engineer's to assist in analysing and locating faults and should only be used in conjunction with other information gathered. **NOTE** when you are in single detector mode the fire alarm system is only polling the actual detector you see on the LCD and all other detectors are inoperative, before leaving Menu-4 you should change the setting back to AUTO TESTING even though normal polling is automatically restarted when you leave MENU mode. The **EVACUATE switch on the front of the control panel will still be fully operational during "Single Detector Polling"**.

15. LMR REPORT

This display shows the "LAST MISSED RESPONSE" from a detector and can be used in tracing intermittent faults on the installation; this feature will only retain the details of the very last detector to give a single mis-response, this mis-response may not be in the log because a detector must mis-respond 4 consecutive times before the log records it as a fault, the number on the top line shows the total quantity of mis-responses from all detectors that have occurred since the counter was last reset to zero, resetting to zero is done by turning the key to RESET.

This display should only be used by knowledgeable engineers to assist in analysing and locating faults and then only in conjunction with other information gathered, large numbers on the "LMR Report" do not necessarily mean the system is faulty as they may have accumulated over a long time.

16. RESTARTS COUNTER

This display shows how many times the system has been re-initialised (i.e. de-powered and re-started) since the counter was last reset, turning the key to RESET resets the counter to zero, the Event Log records every time the system is re-initialised.

17. RETURNING TO DEFAULT SETTINGS.

Resetting the defaults in MENU-4 will not affect :- The Log entries; Location Text; "Detector type" settings; Clock & Calendar.

18. ZONAL RELAYS.

If you fit a Zonal Relay Module each of the 8 relays can be fully tested via Menu-5. In normal operation individual relays will operate when a particular zone LED lights. This feature could be used, for example, 10 to open smoke vents on a single floor level rather than the whole building.

19. ZONED ALARMS.

Each of the Loops can be made to give a continuous alarm on the loop of activation and pulsing alarms on the other loops, this feature is set in Menu-5.

20. SPECIAL WALK-TEST MODE.

When walk-testing the FirePoint normally all of the loops will sound an alarm when triggered then automatically reset, with the Menu-5 setting you can Walk-Test the loop of activation and have the alarm sound only on that Loop, all other Loops will be silent.

21. MAIN ALARM DELAY.

The main alarm sounders can be delayed from sounding for up to 300 seconds by use of this Menu-5 facility. Only use if absolutely necessary.

22. REMOTE ALARM DELAY.

The Remote Evacuate input can be delayed from sounding the alarms for up to 300 seconds by use of this facility. Only use if absolutely necessary.

23. FAULT FINDING and general information

A common mistake which occurs is when you fit a detector onto a loop and accidentally program it onto another loop. If you look at "View Responses" in Menu-1 you will get a message similar to below, where detector 20 should be on Loop-1 but is showing "No Response" and one shows as present on Loop-2 when there shouldn't be any. Re-programming the detector onto Loop-2 instead of Loop-1 will solve the problem. There is no need to de-program detector 20 from Loop-1 just simply move the "Map Change" switch to the ON position and the control panel will "hide" this wrong information from the display.

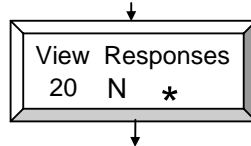

If you add a detector to the installation that has the same address number as an existing detector you will get a message similar to below :-

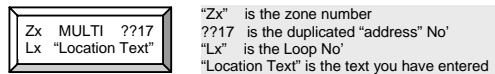

To find a "MULTI" detector:- Usually it's quickest to look for a "missing" detector that **should** be there; go to Menu-1 and use the "VIEW - RESPONSES" display. The "missing" detector has probably been set to the same number as another detector causing the "MULTI" message.

If you add an extra detector to the installation the system will not "see" the new detector until it is in the memory-map, and as such it will not give FIRE or FAULT indications. The display will show the warning - "MAP & INSTALLATION MISMATCHED".

To add the detector into the memory, move the MAP CHANGE switch to the ON position and after a few seconds the message "MAP CHANGE DONE" will appear with the new quantity of detectors on each Loop, move the switch back to the OFF position and the new memory map is saved.

A flashing LED on a detector doesn't mean the detectors in the memory, the map-change switch (Switch-6) must have been put to ON first.



If you were to mistakenly put the positive or negative wire of loop-1 into Loop-2 terminals, and vice versa; the led's on the detectors would still flash but they wouldn't go into FIRE condition, also you would find that on MAP CHANGE there could be the wrong quantity of detectors shown, uncrossing the wires and putting them back in the correct terminals will resolve the problem.

To find a missing detector :- go to Menu-1 and use the "VIEW RESPONSES" display, use the left / right arrows to go through the numbers on each loop, all of the installed detectors will have a "star" symbol to indicate YES, or a "dash" for NO (see section C, part 1).

To check what "address" number a detector is set at, go to VIEW RESPONSES and use the left / right arrows to step through all 64 numbers individually; when you reach the number that the detector is set to it's LED will stay on, in this way you can confirm the correct address setting of every installed detector.

If you get the message "SHORT CIRCUIT ON LOOP 1 (or 2,3,4) disconnect the loop wiring immediately and trace and remove the short circuit, a short circuit on the loops will eventually cause components on the PCB to heat.

If the LCD shows "SOME ZONE LAMPS AREN'T AVAILABLE" you have set a zone LED to an unavailable zone number in MENU-2, the easiest way to find the detector is via "View Population" (Switch-5) where you can view all the settings for every detector.

A detector set as "Not Installed" will behave the same as an isolated detector except that the LCD display will show a FAULT.

24. SYSTEM DEFAULTS (FACTORY SETTINGS)

When the FirePoint-3 control panel arrives it will have a set of factory default settings which are :-

- * All "Detector text" will be displayed as "ADDRESS XX", (where "XX" is the address number you set on the detector switches).
- * The Zone LED allocation will be :- (LOOP 1, ADDRESSES 0-31 = ZONE LED 1) (LOOP 1, ADDRESSES 32-63 = ZONE LED 2)
(LOOP 2, ADDRESSES 0-32 = ZONE LED 3) (LOOP 2, ADDRESSES 33-63 = ZONE LED 4)
(LOOP 3, ADDRESSES 0-31 = ZONE LED 5) (LOOP 3, ADDRESSES 32-63 = ZONE LED 6)
(LOOP 3, ADDRESSES 0-32 = ZONE LED 7) (LOOP 4, ADDRESSES 33-63 = ZONE LED 8)
(The above are just factory test settings, you can change the zone LED's to suit yourself when entering the detector info!.)

- * The LCD will NOT retain the last fault indication.
- * Service Timer will be ON..... Service Interval will be set to 56 WEEKS
- * Default Installer Message will be "FIRE ALARM - SYSTEM NORMAL".
- * REMOTE EVACUATE ringing will be CONTINUOUS (not pulsing)
- * REMOTE & LOCAL EVACUATE relay will be ON (the relay contacts WILL change over when remote evacuate is operated)

25. EXAMPLE CUSTOMER OPERATING INSTRUCTIONS

If the fire alarm system is operating normally the only lights illuminated will be the "SUPPLY ON" indication.

If a FIRE should occur

The main alarm sounders will operate and the control panel will show the exact location of the fire. Evacuate the building avoiding the area where the fire is. Do not Shout, Run, or Panic.

To Silence the alarm sounders

Turn the key-switch to the "SILENCE" position.
(the main alarm sounders will stop and a buzzer in the control panel will sound)

To Reset the system

Turn the key-switch to the "RESET" position.

Note !. If a smoke detector still has smoke inside it or a call-point glass is broken, the alarm will go into its alarm condition again; either ventilate the area or replace the call-point glass as necessary.

If a Fault should occur

The Yellow fault lights will come on and the LCD display window will show what the fault is. Turn control panel key to "SILENCE" to mute the buzzer and contact your service organisation.

To sound an EVACUATION

Press and hold the EVACUATE button and firmly turn the key to RESET at the same time.

←----- Tear off ----->

26. Detector "Address" settings.

To set the "address code" on a detector Base, Call-Point, or Addressable Module set the switches shown to ON, all other switches should be in the OFF position.

Detector Address No'	Set these switches ON	Detector Address No'	Set these switches ON	Detector Address No'	Set these switches ON	Detector Address No'	Set these switches ON
1	1	17	5-1	33	6-1	49	6-5-1
2	2	18	5-2	34	6-2	50	6-5-2
3	2-1	19	5-2-1	35	6-2-1	51	6-5-2-1
4	3	20	5-3	36	6-3	52	6-5-3
5	3-1	21	5-3-1	37	6-3-1	53	6-5-3-1
6	3-2	22	5-3-2	38	6-3-2	54	6-5-3-2
7	3-2-1	23	5-3-2-1	39	6-3-2-1	55	6-5-3-2-1
8	4	24	5-4	40	6-4	56	6-5-4
9	4-1	25	5-4-1	41	6-4-1	57	6-5-4-1
10	4-2	26	5-4-2	42	6-4-2	58	6-5-4-2
11	4-2-1	27	5-4-2-1	43	6-4-2-1	59	6-5-4-2-1
12	4-3	28	5-4-3	44	6-4-3	60	6-5-4-3
13	4-3-1	29	5-4-3-1	45	6-4-3-1	61	6-5-4-3-1
14	4-3-2	30	5-4-3-2	46	6-4-3-2	62	6-5-4-3-2
15	4-3-2-1	31	5-4-3-2-1	47	6-4-3-2-1	63	6-5-4-3-2-1
16	5	32	6	48	6-5	00	All OFF

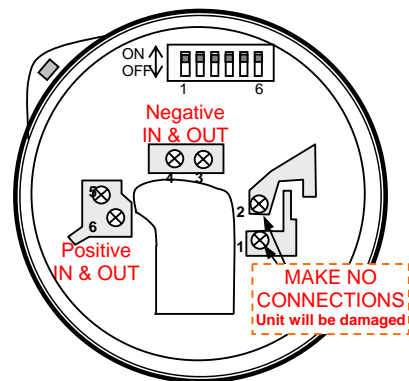

Detector Base
NOTE. Connect base ONLY as shown here.

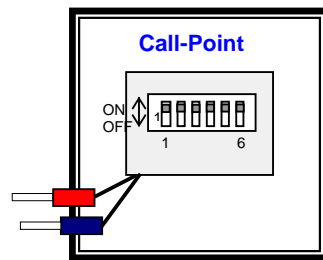

IMPORTANT NOTE !!
Ensure the detector base is mounted on a flat surface so that the electronics are not subject to twisting when the mounting screws are tightened

